

KG

TROLLEY KG						
Capacidade (ton)	Dimensões (mm)				Viga I recomendada	Raio mínimo de curva (m)
	A	B	C	H		
0,5	212	308,5	198,5	113	64 ~140	0,9
1	255	328,5	231,5	128	64 ~140	1,0
2	302	361,5	278	152	76 ~165	1,1
3	344	428,5	338	186	76 ~203	1,3
5	378	434	393	219	88 ~203	1,4
10	455	487,5	490	275,5	125 ~203	2,5
15	642	547	622	315	136 ~203	3,5
20	642	547	622	315	136 ~203	3,5

TROLLEY KG		
Capacidade (ton)	Carga de teste (kg)	Peso bruto (kg)
0,5	0,75	14
1	1,5	19
2	3	29
3	4,5	40
5	7,5	65
10	12,5	103
15	18,8	245
20	25	245

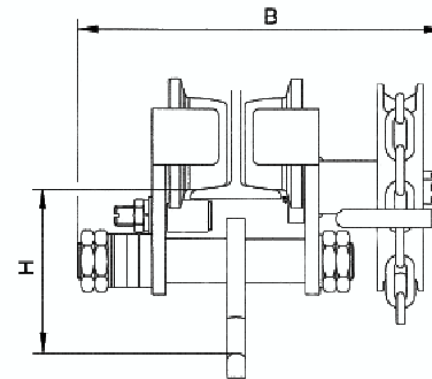
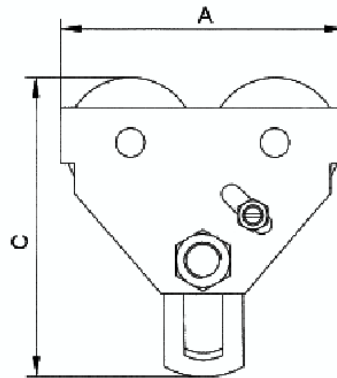

0.5Ton-20Ton